

SPC 024 - Oil Pressure Sensor

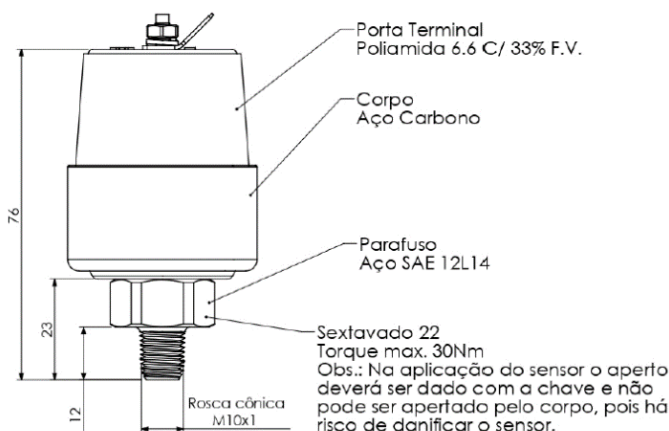

Model	SPC 024
Fluids	DIESEL
Pressure range	0 a 10 Bar (0 a 145 Psi)
Work temperature	- 20 a 115°C
Connection	M10 X 1 Conical
Código VDO	905692000082
Código 3RHO	961050690024
OIL PRESSURE SWITCH SWITCHING PRESSURE	
Alarm Circuit	Normal Closed
Switching 0.8 bar	Pressure increase
Switching 0.5 bar	Pressure decrease
working voltage	12 a 24V
Max power.	5 W
Lifespan	200.000 cycles

Dimensions

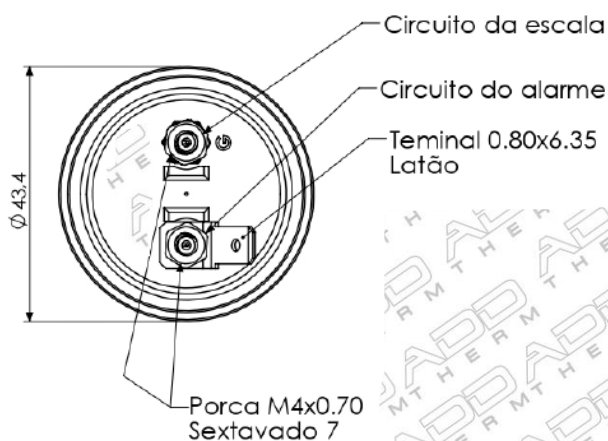

Calibration Table

PRESSURE	0 bar	2 bar	4 bar	6 bar
RESISTANCE	$10 \pm 3 \Omega$	$52 \pm 4 \Omega$	$88 \pm 4 \Omega$	$124 \pm 5 \Omega$

Electric Diagram

ESQUEMA ELECTRICO DE CONEXION

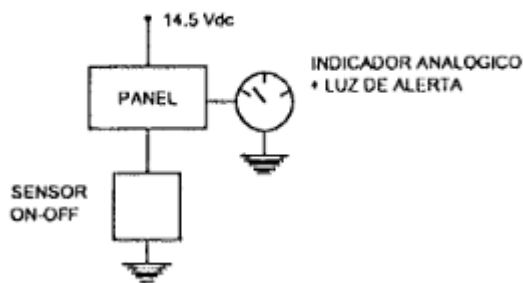

ELECTRIC DIAGRAM

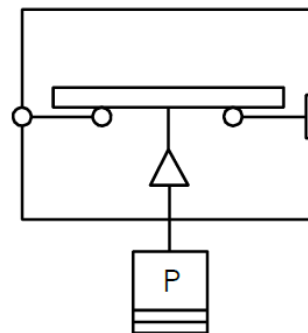

NORMALLY CLOSED